

FEATURES

- Investment casting body and cap
- Maximum Pressure 300 psi (20 BAR)
- Maximum working temperature 446°F (230°C)
- Thread ends conform to ANSI B2.1, BS21, DIN259/2999 standard



SPECIFICATIONS AND INFORMATION

ITEM	PARTS	MATERIALS
1	BODY	ASTM-A351-CF8M
2	CAP	ASTM-A351-CF8M
3	SPRING	AISI 316
4	DISC	AISI 316
5	SEAT	PTFE
6	WASHER	AISI 304
7	NUT	AISI 304
8	JOINT GASKET	PTFE

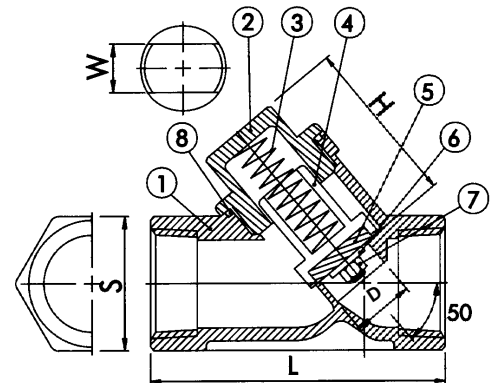

P/N	NOMINAL D	L	S	H	W	Ogontz
1/4"	0.45"	2.57"	1.06"	1.49"	0.94"	OPCV-SS-0025
3/8"	0.49"	2.57"	1.06"	1.49"	0.94"	OPCV-SS-0375
1/2"	0.49"	2.57"	1.06"	1.41"	0.94"	OPCV-SS-0050
3/4"	0.70"	2.97"	1.25"	1.73"	1.18"	OPCV-SS-0075
1"	0.92"	3.56"	1.61"	2.24"	1.37"	OPCV-SS-0100

All dimensions are given in millimeters.

THE OGONTZ GUARANTEE

We will repair or replace on a no-charge basis, F.O.B. Willow Grove, PA, units returned to us within 18 months if found to be defective in material or workmanship.



Ogontz has a policy of continuous product research and improvement, and reserves the right to change design and specifications without notice.

2835 Terwood Road • Willow Grove, PA 19090
 TEL: 215.657.4770 • 1-800-523-2478 • FAX: 215.657.0460
 E-mail: info@ogontz.com • Website: www.ogontz.com